

Free of maintenance stop valve with bellows seal - metallic sealing

ARI-FABA®-ANSI LongLife -

Class 150

Straight through with flanges

• German TA - Luft TÜV-Test-No. 088-945053

SA216WCB

Fig. 031

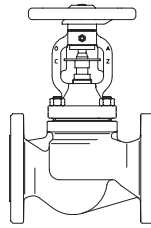

Page 2

ARI-FABA®-ANSI LongLife -

Class 300

Straight through with flanges

• German TA - Luft TÜV-Test-No. 088-945053

SA216WCB

Fig. 041

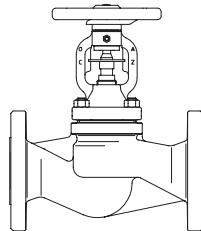

Page 3

ARI-FABA®-ANSI LongLife -

Class 300

Straight through with socket weld ends

• German TA - Luft TÜV-Test-No. 088-945053

SA105

Fig. 049

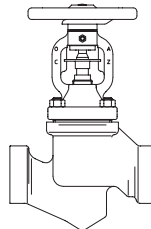

Page 4

ARI-FABA®-ANSI LongLife -

Class 300

Straight through with screwed socket connection

• German TA - Luft TÜV-Test-No. 088-945053

SA105

Fig. 049

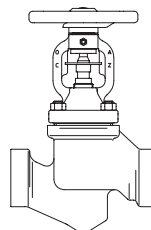

Page 5

FABA®
LONG LIFE

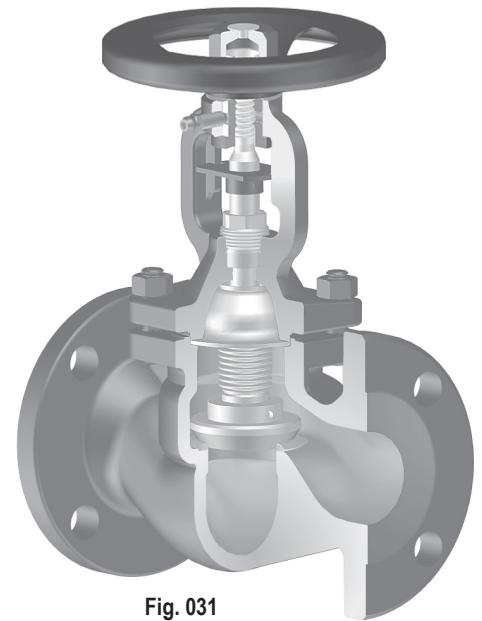

Fig. 031

*For standard casting / forged versions refer to data sheet „FABA® LongLife“
Stainless steel versions refer to data sheet „FABA®-LongLife Stainless steel“*

Features:

- Two-ply bellows seal as standard
- Plug with marginal seat
- DN 15- 80 stem with fine thread as standard
- Lubricating nipple as locking device as standard
- Stem with bellows seal
- Secondary sealing: gland packing
- Position indicator as standard
- Non-rising handwheel
- Non-rotation lock for each nominal diameter
- External stem thread
- Stem with roll hardened thread
- Seat/Plug hardened

ANSI-Stop valve - straight through with flanges and bellows seal - Class 150 (SA216WCB)

Figure-No.	Nominal pressure	Material	Nominal diameter
34.031	ANSI150	SA216WCB	1/2" - 10"
Test: German TA - Luft TÜV-Test-No. 088-945053			
Flanges acc. to ASME / ANSI B16.5			
At high differential pressures a balancing plug is necessary! (refer to page 6)			
Plug with marginal seat standard			

Selection of possible applications

Industry, powerstations, flue gas purification plant, processing technology, gas supply, vapour facilities, recycling facilities, vacuum facilities, hot water, heating technology, district heating, thermal oil applications, general plant manufacturing, etc.
(other applications on request)

Selection of possible flow media

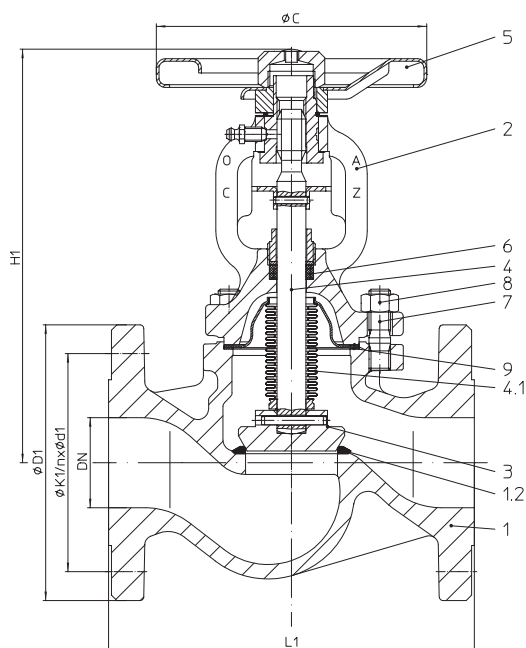
Steam, gases, hot water, thermal oil, process water, vacuum facilities, ammonia etc.
(other flow media on request)

Parts

Pos.	Description	Fig. 34.031
1	Body	SA216WCB
1.2	Seat	E347-16
2	Bonnet	SA216WCB
3	Plug *	AISI440 (vakuumhardened)
4.1	Bellows seal *	SA479Gr.316Ti
4.2	Stem *	AISI420
5	Handwheel	A366 (epoxy-coating)
6	Packing ring *	Pure graphite
7	Stud	SA193-B7
8	Hexagon nut	SA194-2H
9	Gasket *	Pure graphite (CrNi laminated with graphite)

* Spare part

Information / restriction of technical rules need to be observed!

Operating instructions can be ordered by phone +49 (0)5207 / 994-0 or fax +49 (0)5207 / 994-158 or -159.

A production allowance acc. to TRB 801 No. 45 exists

The engineer, designing a system or a plant, is responsible for the selection of the correct valve.

Dimensions

Nominal diameter		1/2"	3/4"	1"	1 1/2"	2"	2 1/2"	3"	4"	6"	8"	10"
L1	(inch)	4,25	4,61	5	6,5	7,99	8,5	9,49	11,5	15,98	19,49	24,49
H1	(inch)	8,07	8,07	8,27	8,86	9,06	9,65	10,43	14,37	16,73	21,65	28,35
ØC	(inch)	4,92	4,92	4,92	5,91	5,91	6,89	8,86	11,81	15,75	20,47	20,47
Travel	(inch)	0,24	0,24	0,31	0,51	0,51	0,63	0,79	0,98	1,57	1,97	2,76
Cv-value	(us-gal)	4,7	8,3	12,8	32,4	51,2	83,7	125,6	197,7	437,2	761,6	1197,7
Nominal diameter		15	20	25	40	50	65	80	100	150	200	250
L1	(mm)	108	117	127	165	203	216	241	292	406	495	622
H1	(mm)	205	205	210	225	230	245	265	365	425	550	720
ØC	(mm)	126	126	126	150	150	175	225	300	400	520	520
Travel	(mm)	6	6	8	13	13	16	20	25	40	50	70
Kvs-value	(m³/h)	4	7,1	11	27,9	44	72	108	170	376	655	1030
Zeta-value	--	4,95	4,95	5,05	5,17	5,07	5,37	5,41	5,31	5,51	5,71	5,70

Standard-flange dimensions refer to page 8

Face-to-face dimension according to ANSI B16.10

Weights

Nominal diameter		1/2"	3/4"	1"	1 1/2"	2"	2 1/2"	3"	4"	6"	8"	10"
34.031	(lbs)	11,4	11,8	12,8	14,3	26,4	46,2	54	88	172	370	572
Nominal diameter		15	20	25	40	50	65	80	100	150	200	250
34.031	(kg)	5,2	5,4	5,8	6,5	12	21	24,5	40,2	78	168	260

ANSI-Stop valve - straight through with flanges and bellows seal - Class 300 (SA216WCB)

Figure-No.	Nominal pressure	Material	Nominal diameter
35.041	ANSI300	SA216WCB	1/2" - 10"
Test: German TA - Luft TÜV-Test-No. 088-945053			
Flanges acc. to ASME / ANSI B16.5			
At high differential pressures a balancing plug is necessary! (refer to page 6)			
Plug with marginal seat standard			

Selection of possible applications

Industry, powerstations, flue gas purification plant, processing technology, gas supply, vapour facilities, recycling facilities, vacuum facilities, hot water, heating technology, district heating, thermal oil applications, general plant manufacturing, etc. (other applications on request)

Selection of possible flow media

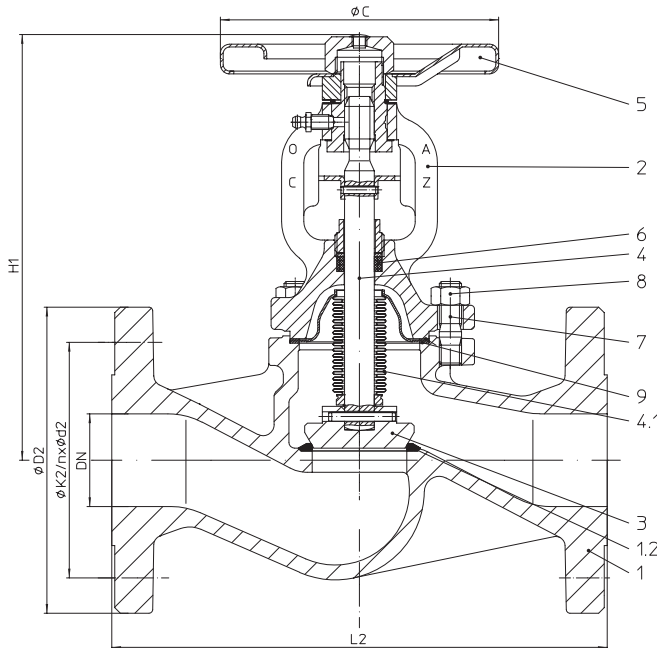
Steam, gases, hot water, thermal oil, process water, vacuum facilities, ammonia etc. (other flow media on request)

Parts

Pos.	Description	Fig. 35.041
1	Body	SA216WCB
1.2	Seat	E347-16
2	Bonnet	SA216WCB
3	Plug *	AISI440 (vakuumhardened)
4.1	Bellows seal *	SA479Gr.316Ti
4.2	Stem *	AISI420
5	Handwheel	A366 (epoxy-coating)
6	Packing ring *	Pure graphite
7	Stud	SA193-B7
8	Hexagon nut	SA194-2H
9	Gasket *	Pure graphite (CrNi laminated with graphite)

* Spare part

Information / restriction of technical rules need to be observed!

Operating instructions can be ordered by phone +49 (0)5207 / 994-0 or fax +49 (0)5207 / 994-158 or -159.

A production allowance acc. to TRB 801 No. 45 exists

The engineer, designing a system or a plant, is responsible for the selection of the correct valve.

Dimensions

Nominal diameter		1/2"	3/4"	1"	1 1/2"	2"	2 1/2"	3"	4"	6"	8"	10"
L2	(inch)	6,98	7,01	7,99	9,02	10,51	11,5	12,52	14,02	17,48	22,01	24,49
H1	(inch)	8,07	8,07	8,27	8,86	9,06	9,65	10,43	14,37	16,73	21,65	28,35
ØC	(inch)	4,92	4,92	4,92	5,91	5,91	6,89	8,86	11,81	15,75	20,47	20,47
Travel	(inch)	0,24	0,24	0,31	0,51	0,51	0,63	0,79	0,98	1,57	1,97	2,76
Cv-value	(us-gal)	5,8	8,7	14	34,9	53,5	89,5	132,6	224,4	468,6	832,6	1264
Nominal diameter		15	20	25	40	50	65	80	100	150	200	250
L2	(mm)	152	178	203	229	267	292	318	356	444	559	622
H1	(mm)	205	205	210	225	230	245	265	365	425	550	720
ØC	(mm)	126	126	126	150	150	175	225	300	400	520	520
Travel	(mm)	6	6	8	13	13	16	20	25	40	50	70
Kvs-value	(m³/h)	5	7,5	12	30	46	77	114	193	403	716	1087
Zeta-value	--	3,1	4,2	4,2	4,4	4,6	4,6	4,8	4,1	4,8	4,8	5,1

Standard-flange dimensions refer to page 8

Face-to-face dimension according to ANSI B16.10

Weights

Nominal diameter		1/2"	3/4"	1"	1 1/2"	2"	2 1/2"	3"	4"	6"	8"	10"
35.041	(lbs)	11,8	13,9	19	21	32,8	50,6	64	108	207	425	649
Nominal diameter		15	20	25	40	50	65	80	100	150	200	250
35.041	(kg)	5,4	6,3	8,6	9,5	14,9	23	29	49,2	94	193	295

ANSI-Stop valve - straight through with socket ends and bellows seal - Class 300 (SA105)

Figure-No.	Nominal pressure	Material	Nominal diameter
45.049....3	ANSI300	SA105	1/2" - 2"
Test: German TA - Luft TÜV-Test-No. 088-945053			
Socket ends according to ASME / ANSI B16.11			
Plug with marginal seat standard			

Selection of possible applications

Industry, powerstations, flue gas purification plant, processing technology, gas supply, vapour facilities, recycling facilities, vacuum facilities, hot water, heating technology, district heating, thermal oil applications, general plant manufacturing, etc.
(other applications on request)

Selection of possible flow media

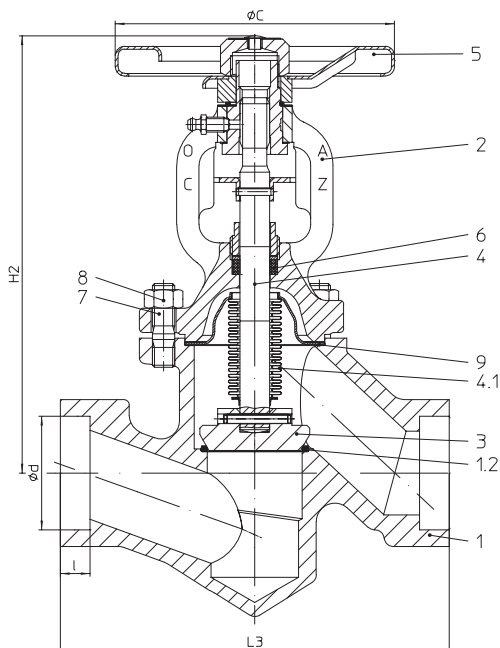
Steam, gases, hot water, thermal oil, process water, vacuum facilities, ammonia etc.
(other flow media on request)

Parts

Pos.	Description	Fig. 45.049....3
1	Body	SA105
1.2	Seat	E347-16
2	Bonnet	SA105
3	Plug *	AISI440 (vakuumhardened)
4.1	Bellows seal *	SA479Gr.316Ti
4.2	Stem *	AISI420
5	Handwheel	A366 (epoxy-coating)
6	Packing ring *	Pure graphite
7	Stud	SA193-B7
8	Hexagon nut	SA194-2H
9	Gasket *	Pure graphite (CrNi laminated with graphite)

* Spare part

Information / restriction of technical rules need to be observed!

Operating instructions can be ordered by phone +49 (0)5207 / 994-0 or fax +49 (0)5207 / 994-158 or -159.

A production allowance acc. to TRB 801 No. 45 exists

The engineer, designing a system or a plant, is responsible for the selection of the correct valve.

Dimensions

Nominal diameter		1/2"	3/4"	1"	1 1/4"	1 1/2"	2"
L3	(inch)	4,61	4,61	5,47	7,32	7,32	8,23
H2	(inch)	7,99	7,99	8,46	9,06	9,06	9,45
ØC	(inch)	4,92	4,92	4,92	4,92	5,91	5,91
Travel	(inch)	0,24	0,24	0,31	0,51	0,51	0,51
Cv-value	(us-gal)	3,6	6,4	10	14,9	23,3	30,2
Nominal diameter		15	20	25	32	40	50
L3	(mm)	117	117	139	186	186	209
H2	(mm)	203	203	215	230	230	240
ØC	(mm)	126	126	126	150	150	150
Travel	(mm)	6	6	8	13	13	13
Kvs-value	(m³/h)	3,1	5,5	8,6	12,8	20	26
Zeta-value	--	8,1	8,1	8,1	8,5	9,8	14,2

Socket weld ends dimensions refer to page 8

Face-to-face dimension according to ANSI B16.10

Weights

Nominal diameter		1/2"	3/4"	1"	1 1/4"	1 1/2"	2"
45.049....3	(lbs)	6,4	6,4	8,14	13	13	16,1
Nominal diameter		15	20	25	32	40	50
45.049....3	(kg)	2,9	2,9	3,7	5,9	5,9	7,3

ANSI-Stop valve - straight through with screwed socket and bellows seal - Class 300 (SA105)

Figure-No.	Nominal pressure	Material	Nominal diameter
45.049....2	ANSI300	SA105	1/2" - 2"
Test: German TA - Luft TÜV-Test-No. 088-945053			
Screwed sockets acc. to DIN ISO 228 (BSP) or acc. to ASME / ANSI B1.20.1 (NPT)			
Plug with marginal seat standard			

Selection of possible applications

Industry, powerstations, flue gas purification plant, processing technology, gas supply, vapour facilities, general plant manufacturing, etc.

(other applications on request)

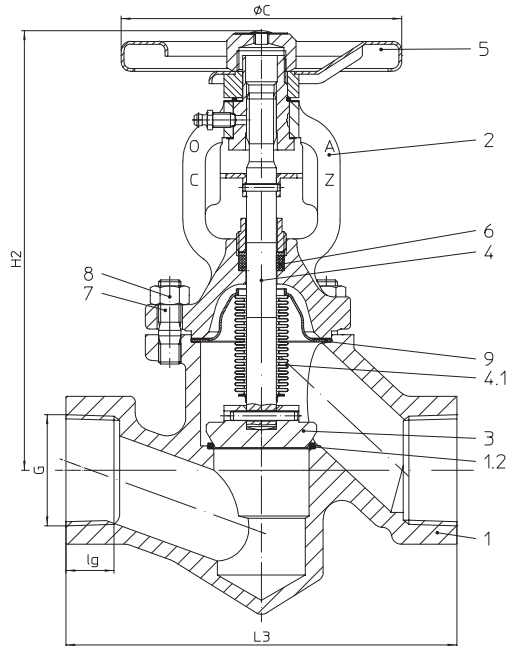
Selection of possible flow media

Steam, gases, hot water, etc.

(other flow media on request)

Parts

Pos.	Description	Fig. 45.049....2
1	Body	SA105
1.2	Seat	E347-16
2	Bonnet	SA105
3	Plug *	AISI440 (vakuumhardened)
4.1	Bellows seal *	SA479Gr.316Ti
4.2	Stem *	AISI420
5	Handwheel	A366 (epoxy-coating)
6	Packing ring *	Pure graphite
7	Stud	SA193-B7
8	Hexagon nut	SA194-2H
9	Gasket *	Pure graphite (CrNi laminated with graphite)

* Spare part

Information / restriction of technical rules need to be observed!

Operating instructions can be ordered by phone +49 (0)5207 / 994-0 or fax +49 (0)5207 / 994-158 or -159.

A production allowance acc. to TRB 801 No. 45 exists

The engineer, designing a system or a plant, is responsible for the selection of the correct valve.

Dimensions

Nominal diameter		1/2"	3/4"	1"	1 1/4"	1 1/2"	2"
L3	(inch)	4,61	4,61	5,47	7,32	7,32	8,23
H2	(inch)	7,99	7,99	8,46	9,06	9,06	9,45
ØC	(inch)	4,92	4,92	4,92	4,92	5,91	5,91
Travel	(inch)	0,24	0,24	0,31	0,51	0,51	0,51
Cv-value	(us-gal)	3,6	6,4	10	14,9	23,3	30,2
Nominal diameter		15	20	25	32	40	50
L3	(mm)	117	117	139	186	186	209
H2	(mm)	203	203	215	230	230	240
ØC	(mm)	126	126	126	150	150	150
Travel	(mm)	6	6	8	13	13	13
Kvs-value	(m³/h)	3,1	5,5	8,6	12,8	20	26
Zeta-value	--	8,1	8,1	8,1	8,5	9,8	14,2

Screwed socket dimensions refer to page 8

Face-to-face dimension according to ANSI B16.10

Weights

Nominal diameter		1/2"	3/4"	1"	1 1/4"	1 1/2"	2"
45.049....2	(lbs)	6,4	6,4	8,14	13	13	16,1
Nominal diameter		15	20	25	32	40	50
45.049....2	(kg)	2,9	2,9	3,7	5,9	5,9	7,3

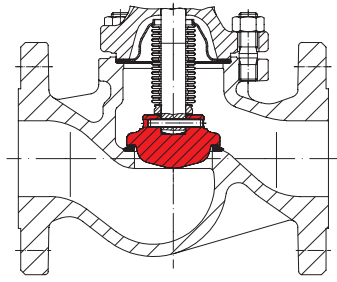

Regulating plug
(for max. permissible ΔP refer to: Flow diagram)

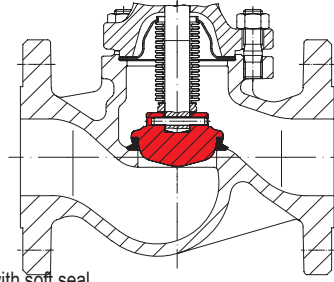

Regulating plug with soft seal
Max. operating temperature 392°F / 200°C at PTFE + 25% carbon
(for max. permissible ΔP refer to: Flow diagram)

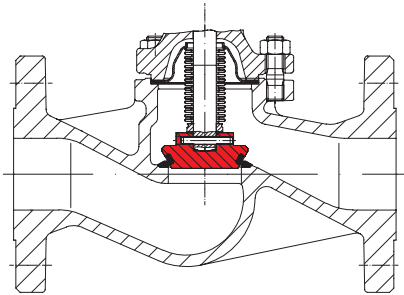

Isolation plug with marginal seat; stellite seat and plug (Stellit 6) /
Seat stellite (Stellit 21)

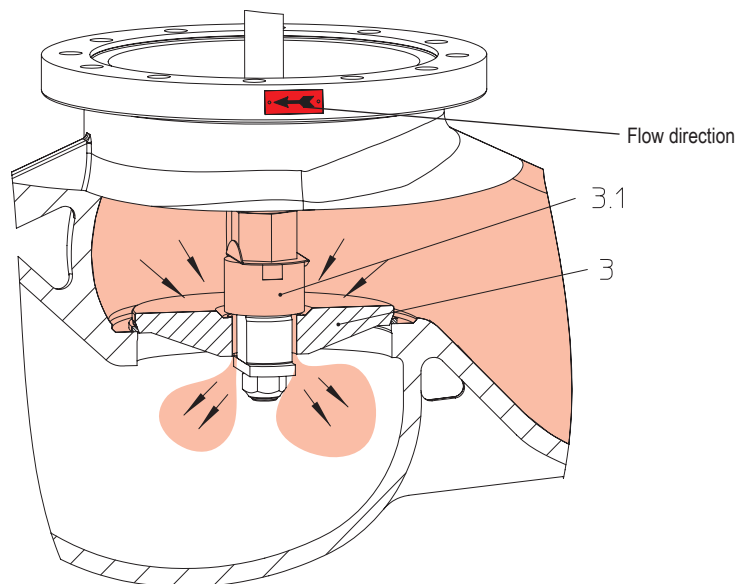

Valves with balancing plugs have to be installed with medium flowing over the plug (3) as indicated by flow direction arrow on valve body.

Working principles:

When the valve is closed, anticlockwise rotation of the hand wheel lifts the pilot plug (3.1) off the larger balancing plug (3).

This allows the medium to pass through the plug and equalizes the pressure of the medium under the plug (3). After the pressures have been equalized within the values stated in the table, the valve can be opened by turning the valve further with normal manual force.

Balancing plugs are fully effective only in closed systems.

The pressures of the medium on either side of the plug can not be equalized if the medium is discharged into open air.

A bypass line or some other arrangement is necessary if too much time is required for pressure equalization owing to the volume in the piping system.

ARI-stop valves with differential pressures exceeding the following pressures, have to be fitted with pressure balancing plugs

Nominal diameter		6"	8"	10"
Differential pressure (ΔP)	(psi)	305	203	131
Nominal diameter		150	200	250
Differential pressure (ΔP)	(bar)	21	14	9

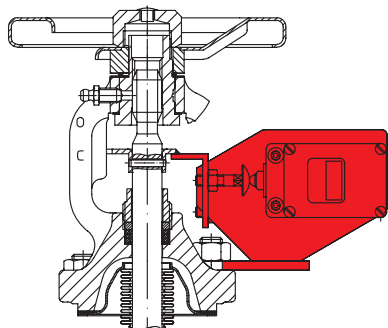

Limit switch

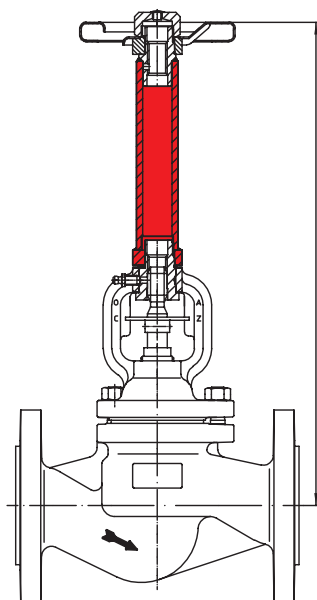

Stem extension (please specify height in your order)

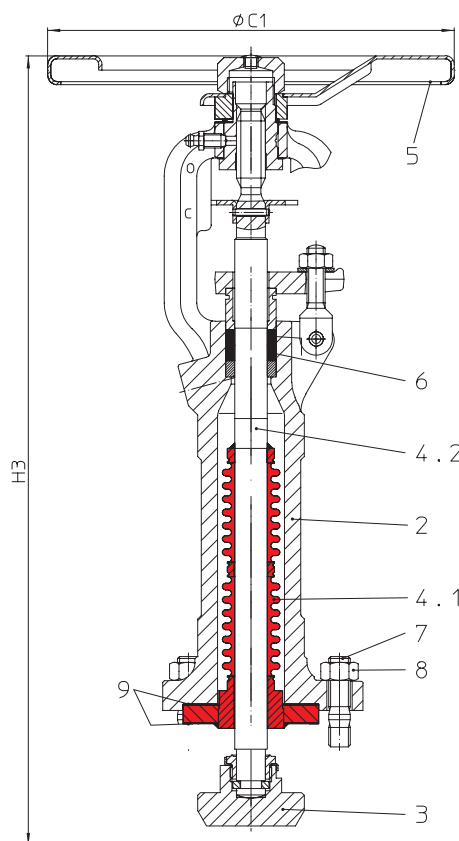

Alternative construction: bellows seal out of media flow path (bellows seal housing in PN40).
(Locking device and travel limiter as accessories)

Dimensions

Nominal diameter		1/2"	3/4"	1"	1 1/2"	2"	2 1/2"	3"	4"	6"	8"	10"
H3	(inch)	12,8	12,8	13,19	16,93	17,13	17,72	18,11	24,41	26,77	32,68	36,02
ØC1	(inch)	6,89	6,89	6,89	8,86	8,86	8,86	8,86	11,81	15,75	20,47	20,47
Nominal diameter		15	20	25	40	50	65	80	100	150	200	250
H3	(mm)	325	325	335	430	435	450	460	620	680	830	915
ØC1	(mm)	175	175	175	225	225	225	225	300	400	520	520

Standard: Lubricating nipple, locking device

Accessories: Travel limiter

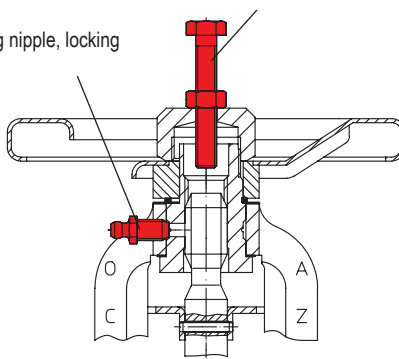

Lubricating nipple / locking device / travel limiter

Application of lubricating nipples

Functions:

1. Lubrication (prevents the handwheel jamming)
2. Locking screw (allows valve to be locked-off at desired travel)
3. Lubrication an locking (lubrication with locked handwheel possible)

Travel limiter
(Accessories are not included !)

Nominal diameter	Hexagon screw	
(inch)	(mm)	(mm x mm)
1/2" - 3"	15-80	M8 x 55
4"	100	M12 x 70
6"	150	M12 x 80
8"	200	M12 x 100
10"	250	M12 x 120

Standard-flange dimensions

Flanges acc. to ANSI B16.5

Nominal diameter		(inch)	1/2"	3/4"	1"	1 1/2"	2"	2 1/2"	3"	4"	6"	8"	10"
ANSI150	ØD1	(inch)	3,5	3,9	4,25	5	6	7	7,52	9	11	13,5	16
ANSI150	ØK1	(inch)	2,36	2,76	3,1	3,86	4,76	5,51	5,98	7,52	9,49	11,73	14,25
ANSI150	n x Ød1	(n x inch)	4 x 0,63	4 x 0,63	4 x 0,63	4 x 0,63	4 x 0,75	4 x 0,75	4 x 0,75	8 x 0,75	8 x 0,87	8 x 0,87	12 x 0,98
ANSI300	ØD2	(inch)	3,74	4,61	4,88	6,1	6,5	7,52	8,27	10	12,52	15	17,52
ANSI300	ØK2	(inch)	2,62	3,25	3,5	4,49	5	5,87	6,61	7,87	10,63	12,99	15,24
ANSI300	n x Ød2	(n x inch)	4 x 0,63	4 x 0,75	4 x 0,75	4 x 0,87	8 x 0,75	8 x 0,87	8 x 0,87	8 x 0,87	12 x 0,87	12 x 0,98	16 x 1,14
Nominal diameter		(mm)	15	20	25	40	50	65	80	100	150	200	250
ANSI150	ØD1	(mm)	89	99	108	127	153	178	191	229	279	343	406
ANSI150	ØK1	(mm)	60	70	79	98	121	140	152	191	241	298	362
ANSI150	n x Ød1	(n x mm)	4 x 16	4 x 16	4 x 16	4 x 16	4 x 19	4 x 19	4 x 19	8 x 19	8 x 22	8 x 22	12 x 25
ANSI300	ØD2	(mm)	95	117	124	155	165	191	210	254	318	381	445
ANSI300	ØK2	(mm)	66,5	82,5	89	114	127	149	168	200	270	330	387
ANSI300	n x Ød2	(n x mm)	4 x 16	1 4 x 9	4 x 19	4 x 22	8 x 19	8 x 22	8 x 22	8 x 22	12 x 22	12 x 25	16 x 29

Socket weld ends dimensions

Nominal diameter		(inch)	1/2"	3/4"	1"	1 1/4"	1 1/2"	2"
ANSI300	l	(inch)	0,39	0,51	0,51	0,51	0,51	0,63
ANSI300	Ød	(inch)	0,85	1,07	1,33	1,67	1,92	2,41
Nominal diameter		(mm)	15	20	25	32	40	50
ANSI300	l	(mm)	10	13	13	13	13	16
ANSI300	Ød	(mm)	21,7	27,1	33,8	42,5	48,7	61,1

Screwed socket dimensions

Nominal diameter		(inch)	1/2"	3/4"	1"	1 1/4"	1 1/2"	2"
ANSI300	lg	(inch)	0,59	0,64	0,75	0,84	0,84	1,01
ANSI300	G (BSP)	(inch)	1/2	3/4	1	1 1/4	1 1/2	2
ANSI300	G (NPT)	(inch)						
Nominal diameter		(mm)	15	20	25	32	40	50
ANSI300	lg	(mm)	15	16,3	19,1	21,4	21,4	25,7
ANSI300	G (BSP)	(mm)	1/2	3/4	1	1 1/4	1 1/2	2
ANSI300	G (NPT)	(mm)						

Pressure-temperature-ratings acc. to ANSI

Material	Nominal pressure		-20°F to 100°F	200°F	300°F	400°F	500°F	600°F	650°F	700°F	750°F	800°F
SA216WCB / SA105	ANSI150	psi	285	260	230	200	170	140	125	110	95	80
SA216WCB / SA105	ANSI300	psi	740	675	655	635	600	570	550	530	505	410
Material	Nominal pressure		-29°C to 38°C	93°C	149°C	204°C	260°C	315°C	343°C	371°C	399°C	427°C
SA216WCB / SA105	ANSI150	bar	19,6	17,9	15,8	13,8	11,7	9,6	8,69	7,6	6,6	5,5
SA216WCB / SA105	ANSI300	bar	51,1	46,6	45,2	43,8	41,4	39,3	37,9	36,6	34,8	28,3

Intermediate values for max. permissible operational pressures can be determined by linear interpolation of the given temperature / pressure chart.

Please indicate when ordering

- Figure-No.
- Nominal pressure
- Nominal diameter
- Special design / accessories

Example:

Figure 35.031; Class 150; Nominal diameter 4".

Dimensions in inch	1 inch Δ 25,4 mm
Dimensions in mm	
Weights in lbs	1 lbs Δ 0,45 kg
Weights in kg	
Pressures in psig	14,5 psi Δ 1 bar
Pressures in barg	
1 bar Δ 10 ⁵ Pa Δ 0,1 MPa	
Cv in us-gallons/min	0,86 Cv Δ 1 Kvs
Kvs in m ³ /h	



Technology for the Future.
GERMAN QUALITY VALVES

ARI-Armaturen Albert Richter GmbH & Co. KG, D-33756 Schloß Holte-Stukenbrock,
Tel. +49 52 07 / 994-0, Telefax +49 52 07 / 994-158 or 159 Internet: <http://www.ari-armaturen.com> E-mail: info.vertrieb@ari-armaturen.com